

表135 : EGM-W, EGM-WLシリーズ寸法表

標準型	型番	組合せ寸法				ペアリング寸法						
		H	Ho	To	W	L	w	ℓ	L1	F	M × ℓ1	T
EGM5W	EGM5W-MF	6.5	1.5	3.5	17	21.1	13	—	15.1	5	M2.5 × 1.5	10
EGM5WL	EGM5WL-MF					27.2	13	—	21.2		M3	
EGM7W	EGM7W-MF	9	2	5.5	25	31.8	19	10	21.2	7	M3 × 3	14
EGM7WL	EGM7WL-MF					40.5	19	19	30.1			
EGM9W	EGM9W-MF	12	3.4	6	30	39.1	21	12	27.9	8.6	M3 × 3	18
EGM9WL	EGM9WL-MF					50.7	23	24	39.4			
EGM12W	EGM12W-MF	14	3.9	8	40	44.5	28	15	31.1	10.1	M3 × 3.5	24
EGM12WL	EGM12WL-MF					59.6	28	46				
EGM15W	EGM15W-MF	16	4	9	60	55.8	45	20	38.5	12	M4 × 4.5	42
EGM15WL	EGM15WL-MF					74.5	45	35	57.6			

表136 : 標準レール長さ

型番	レール長さ (mm)											
	100	200	300	400	500	600	700	800	900	1000		
EGM5W	55	95	135	175	215	255	295	335	375	415	455	495
EGM5WL	75	115	155	195	235	275	315	355	395	435	475	
EGM7W	50	110	170	230	290	350	410	470				
EGM7WL	80	140	200	260	320	380	440	500				
EGM9W	50	110	170	230	290	350	410	470				
EGM9WL	80	140	200	260	320	380	440	500				
EGM12W	70	150	230	310	390	470						
EGM12WL	110	190	270	350	430							
EGM15W	110	190	270	350	430							
EGM15WL	150	230	310	390	470							

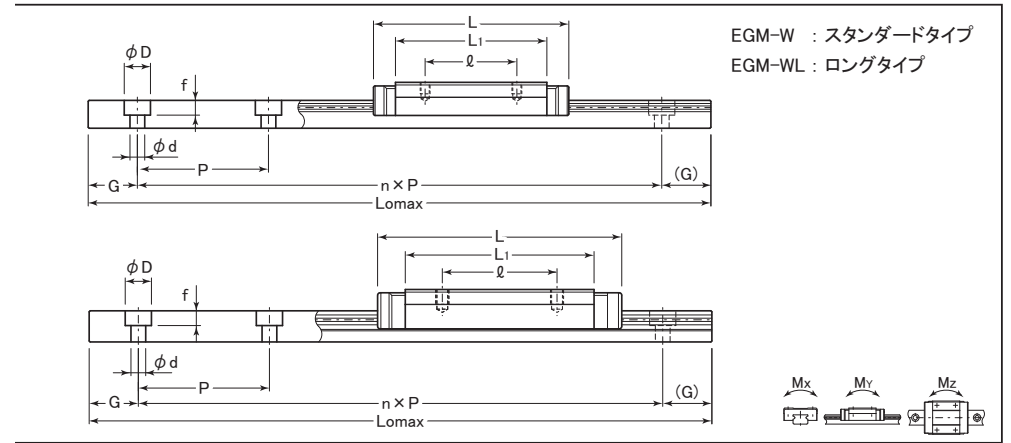
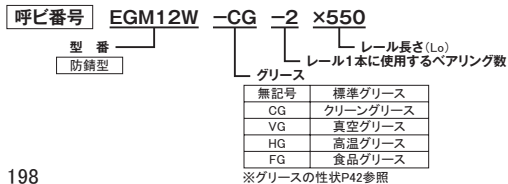

EGM-W : スタンダードタイプ
EGM-WL : ロングタイプ

単位 : mm

レール寸法						基本定格荷重		静的許容モーメント			ペアリング質量	
h	t	P	G	D × d × f	Lomax	C (N)	Co (N)	Mx (N·m)	My (N·m)	Mz (N·m)	質量 (kg)	質量 (kg/m)
4	-	20	7.5	5.5 × 3 × 1.6	1000	623	1040	4.6	2.2	2.2	0.006	0.280
						788	1456	6.8	4.1	4.1	0.008	0.280
5.2	-	30	10	6 × 3.5 × 3.5	1000	1512	2272	15.0	7.3	7.3	0.019	0.516
						1970	3320	22.6	14.9	14.9	0.027	0.516
7.3	-	30	10	6 × 3.5 × 4.5	1000	2603	3883	33.2	13.7	13.7	0.037	0.940
						3341	5547	45.9	26.7	26.7	0.051	0.940
8.5	-	40	15	8 × 4.5 × 4.5	1000	3766	5200	63.7	26.3	26.3	0.065	1.472
						5001	7801	95.6	56.4	56.4	0.093	1.472
9.5	23	40	15	8 × 4.5 × 4.5	1000	6267	8388	171.1	45.7	45.7	0.137	2.818
						8323	12582	257.6	93.1	93.1	0.200	2.818

単位 : mm

レール最大長さ	長さ (mm)											
	600	700	800	900	1000	1100	1200	1300	1400	1500		
1000	535	575	615	655	695	735	775	815	855	895	935	975
	515	555	595	635	675	715	755	795	835	875	915	955
1000	530	590	650	710	770	830	890	950				
	560	620	680	740	800	860	920	980				
1000	530	590	650	710	770	830	890	950				
	560	620	680	740	800	860	920	980				
1000	510	590	670	750	830	910	990					
	510	590	670	750	830	910	990					
1000	550	630	710	790	870	950						
	510	590	670	750	830	910	990					

EGM5W(-MF), 5WL(-MF)のレールを固定するネジは、精密機器用十字穴付き小ネジ (O番なべ小ネジ1種) M2.5 × 7を使用して下さい。

